



HOSHIZAKI

> **IM-220AA**

daily ice production capacity of up to 220kg



Cube ice is perfectly symmetrical and leaves a good impression with its hard, crystal clear quality that melts very slowly; allowing customers to enjoy their favourite drink longer. The I-Fit series of cube ice maker produces standard size ice (28x28x32mm) that is applicable in many settings and designed for uncomplicated usage from start to finish.



> **IM-220AA**
(With Hoshizaki Storage Bin - **B-301SA**)

CUBE ICE MAKER SERIES

I-FIT
SERIES

FEATURES

- > sharp stainless steel exterior
- > easy to remove pull-out filter for cleaning
- > smart computer board technology



UNIQUE ICE PRODUCTION SYSTEM

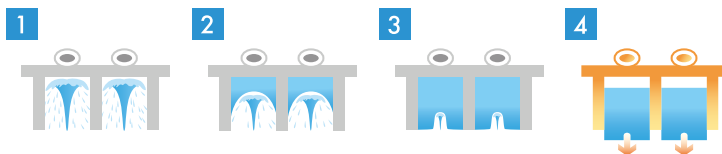

ICE SIZE

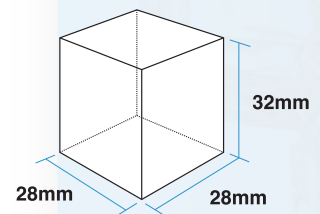

DIMENSIONS & SPECIFICATION

CUBE ICE MAKER AIR SYSTEM

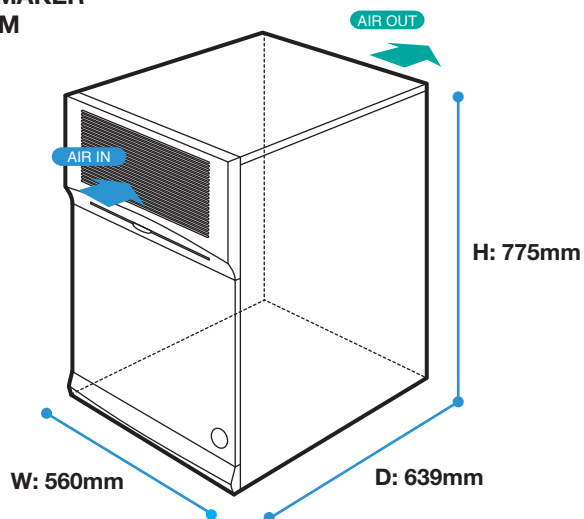

BACK VIEW

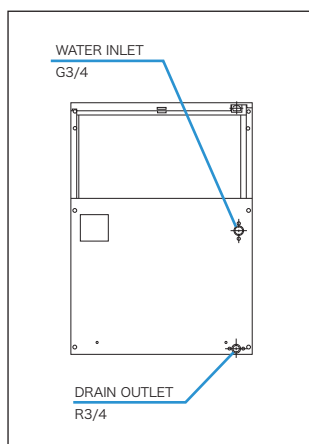

MODEL NAME		IM-220AA
ICE DIMENSIONS (MM) (W x D x H)		28 x 28 x 32
DIMENSIONS (MM) (W x D x H)		560 x 639 x 775
PACKED DIMENSIONS (MM) (W x D x H)		644 x 728 x 883
WEIGHT (NETT/GROSS)		69 KG / 76 KG
AMPERAGE / STARTING AMPERAGE		5.0A / 24A
ELECTRICAL CONSUMPTION		950 W
REFRIGERANT CHARGE		R404a
HEAT REJECTION (AT32°C/WT21°C)		2290 W (1970 kcal/h)
ICE PRODUCTION PER 24H (15MM)	(AT10°C/WT10°C)	220 KG
	(AT21°C/WT15°C)	200 KG
	(AT32°C/WT21°C)	175 KG
WATER CONSUMPTION PER 24H (AT21°C/WT15°C)		0.31 m ³ 1.7L / 1KG ICE
ICE PRODUCTION (AT21°C/WT15°C)	FREEZE CYCLE TIME	23 MIN
	PER CYCLE	3.2 KG / 140 PCS

• WARRANTY:

Two years parts & labour for entire unit, 3rd year on compressor only. Excluding door & exterior damages

OPERATING CONDITIONS: • Voltage Range: ±6% • Ambient Temperature: 1°-40°C

• Water Supply: 5°-35°C / 0.07-0.8 Mpa / 7.25-116 PSI • AC Supply Voltage: 1/220-240V / 50 Hz